

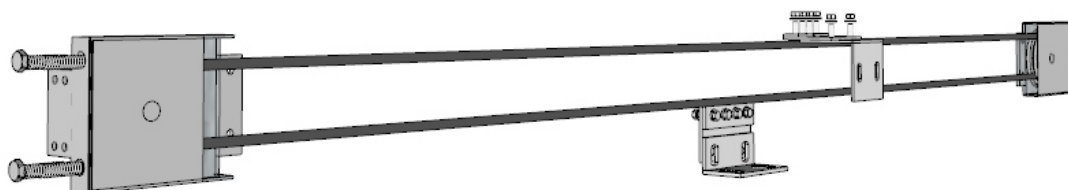

# Installation Manual Clydsdale 500 **APC Telescopic Gate System**



**This installation manual should be considered as a guide only, it cannot account for many of the installation variables which may affect part placements, measurements, sizing etc.**

**Please always use your own discretion as an installer to double check, temporarily fix and test prior to final fitting.**

## Automating a Telescopic Gate

The telescopic gate systems is unlike the normal sliding gate, it is important to use a high capacity motor with 1600kg rating or above. It is recommended to use either the APC-SG1600AC (1.6 Tonne) the APC-SG3000AC (3 Tonne).

## About The Clydsdale 500 System

The APC Clydsdale 500 Telescopic gate systems kit is unique to all other telescopic kits.

Whilst many others require the pulley to be bolted through the gate the Clydsdale 500 system has its pulley and sealed bearing enclosed within an adjustable carrier. The key benefits of such a setup is aside from the quality parts used it also allows for the installer to adjust final cable tension from either end of the gate NOT reaching between the gates.

Furthermore the Anchor bracket has two options for height to suit both recessed type wheel and flat mounted bolt on type wheels.

Finally the trailing bracket is adjustable in depth to allow for a smaller and larger gap between the gates based on the final gate guiding system.

It has all been tried and tested to make the most robust product with the easiest and most flexible installation system.

## Specifications

Max. Gate Width	4600mm
Max. Driveway Width	8500mm
Gate Weight Max.	250Kg Each
Replacement bearing size	32mm OD -15mm ID - 9mm Thick - Deep Groove Ball bearing 6002
Cable	10m, 4mm Stainless Steel

## Recommended Sizing and Material

The telescopic gate systems is unlike the normal sliding gate, it is important to try to keep the weight down to a minimum due to the pulling forces required between leading and trailing gate

We suggest to use 40x40 or 50x50 RHS while the bottom rail must be at 80x40mm, 75x50mm or 100x50mm.

When possible use light weight steel or Aluminium to keep the weight down.

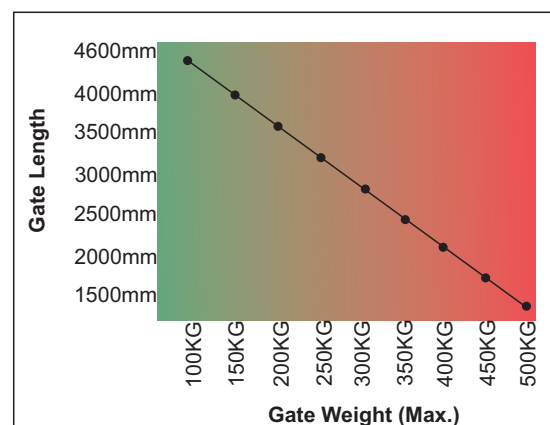

## Supplied Parts

**A** **Adjustable Pulley Carrier Assemblies**  
Fitted to the FRONT side of the gate closest to the motor (Drive Gate) on each side of the gate

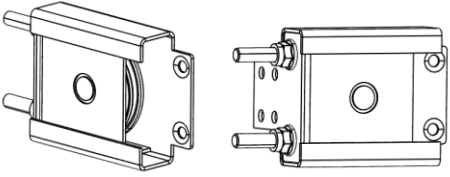

**F** **12x Self Drilling Tek Screw (M6 25mm)**

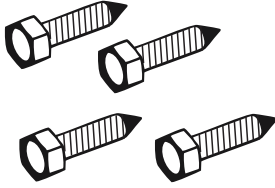

**H** **4x Dynabolts (M8 80mm)**

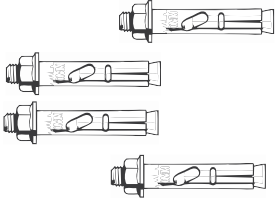

**B** **Trailing Bracket**  
Fitted to the REAR side of the gate closest to the street (Slave Gate)

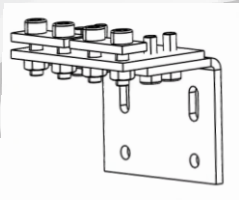

**G** **4x Self Drilling Countersunk Screws (M6 25mm)**

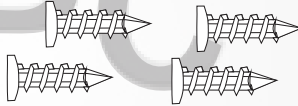

**C** **PRE-ASSEMBLED Raised Bracket + Anchor Bracket**  
Anchored to the Concrete between both the gates for Flat Mount Wheels

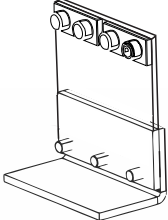

**D** **Lowering Plate**  
Anchored to the Concrete between both the gates using the anchor bracket from part C for Recess Mount Wheels

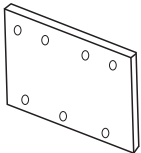

**E** **4mm Stainless Steel Cable (10m Length)**

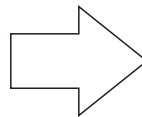
**C + D**

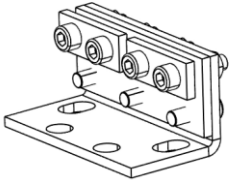

**Lowering Plate + Anchor Bracket Combined Set**  
Anchored to the Concrete between both the gates for Recess Mount Wheels

## Gate and Post Positioning

### Guiding using an Angle OR Z Channel

Posts layout when using “Z” Channels for upright retaining of the gates or have welded angles to the rear of the gate.

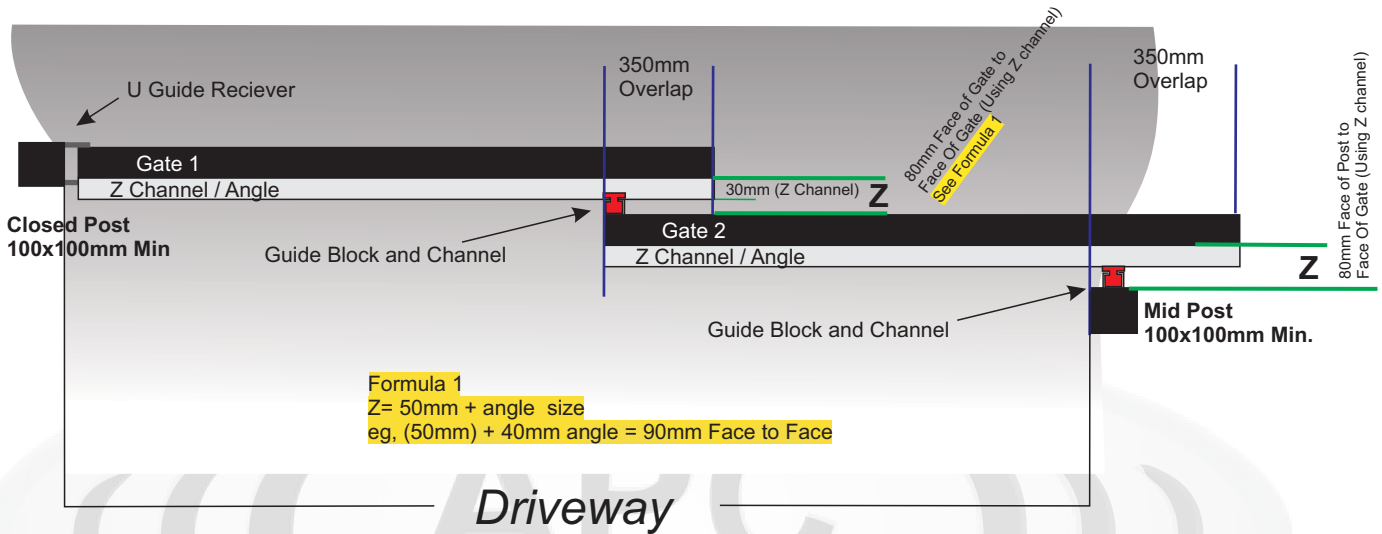

### Guiding using Roller & Bracket Sets

Posts layout when using a Rollers and Brackets for upright retaining of the gates.

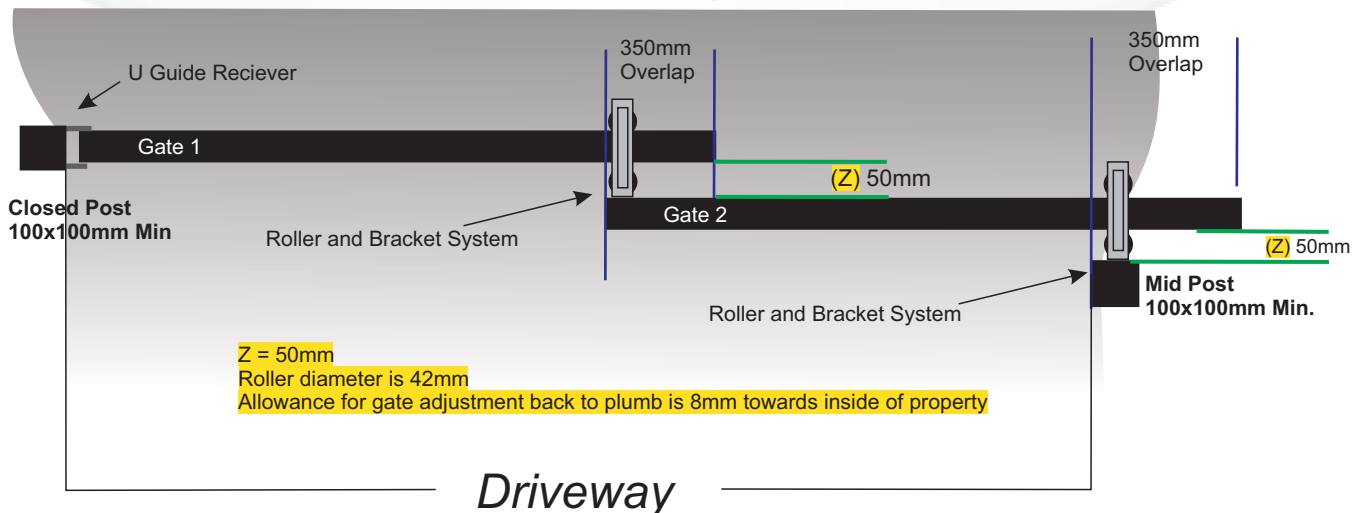

### Calculating Your Gate Sizes

Driveway width  $\div 2 =$  (gate base size)  
 Take the (gate base size) and add 350mm.

#### Example calculation

Driveway width is 4000mm  $\div 2 =$  (2000mm base size)  
 (2000mm base size) + 350mm = 2350mm each gate

### Calculating Your Floor Track Requirements

Gate 1: Driveway width + Final gate Size  
 Gate 2: Final gate size x 2

#### Example calculation

Gate 1: Driveway size is (4000mm) + Final gate size (2350mm) gate 1 requires 6350mm total track  
 Gate 2: If final gate size is (2350mm) x 2 then gate 2 requires 4700mm of track

### Post Offset

#### Closed Post to Mid Post Offset

Gate 1 Depth + Z + Gate 2 Depth + Z = Front Face of Gate 1 from Front Face of Mid Post

## Wheel Positions and Fitting

There are two types of gates wheels available to use:

Option 1: **RECESS WHEELS** (GWRM-78)

Option 2: **FLAT MOUNT WHEELS** (GWFM-78)

Based on the wheel type we use in the installation this will determine how we configure the anchor bracket assembly, this is covered in the next section.

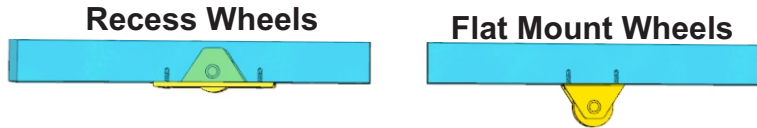

### Wheel Cut Out

If Recess mount wheels are used; Make two wheels cuts 90mm x 35mm in the bottom rail approx.400- 500mm away from the ends of the gate. Slot the wheel in place and fix using 10mm Tek screws.

To install the Flat mount wheels are used then there is no need for the wheels cut out and they will bolt in place using 10mm Tek screws.

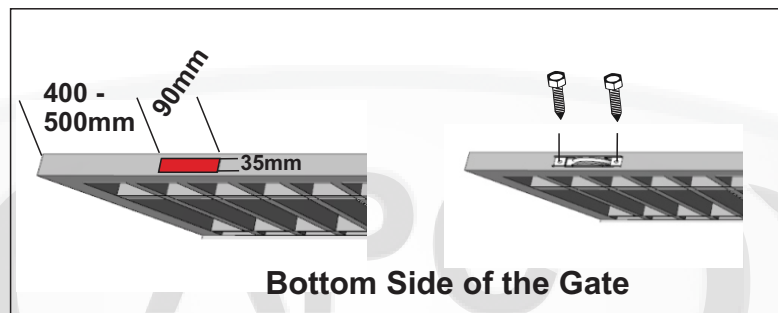

## Preparing the Anchor Bracket

Based on the wheel type chosen assemble your anchor bracket as per below.

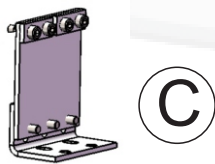

**Flat Mount Wheels**  
Using bracket "C" **RAISED BRACKET**  
PREASSEMBLED



**Recess Mount Wheels**  
Using bracket "C" **RAISED BRACKET**, remove  
raised plate and install Lowering Plate "D"

## Z Channel Fitting

Install the Z Channel to the inside face of the top rail of each of the gates, use 6mm wafer head screws.

Do not use Tek screws or and screw with a larger head as they will touch on the guide block system .

The Z Channel should be install to the entire width of the gate.

There are no holes pre-drilled in the Z channel so please drill according to your screw placement, one screw every 400mm would be recommended.

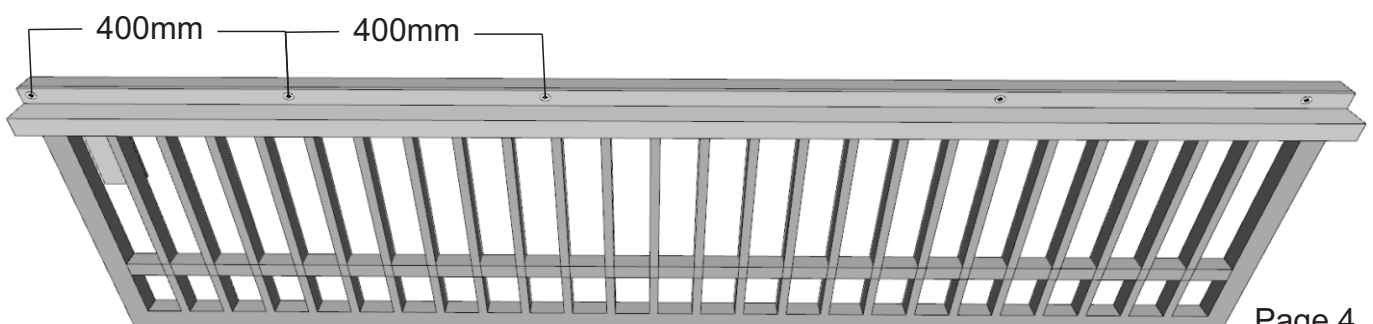

## Preparing the Pulley Carriers

The pulley carriers come pre-assembled but it is recommended that you have each of the carriers set 20mm through there adjustment range so that at the end of the installation process when final tensioning occurs you can loosen/tighten to achieve the correct tension.

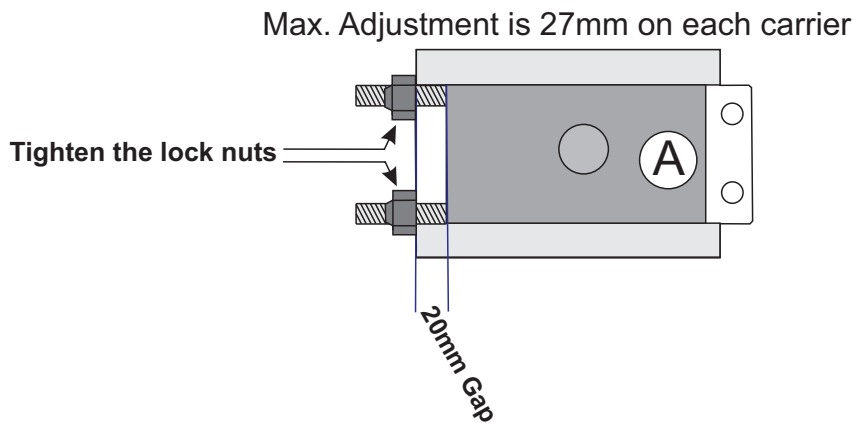

## Installation of Pulley Carrier on Drive Gate

Install the Pulley carrier assembly (A) to each side of the DRIVE GATE bottom rail using the self drilling metal screws supplied (F) and (G).

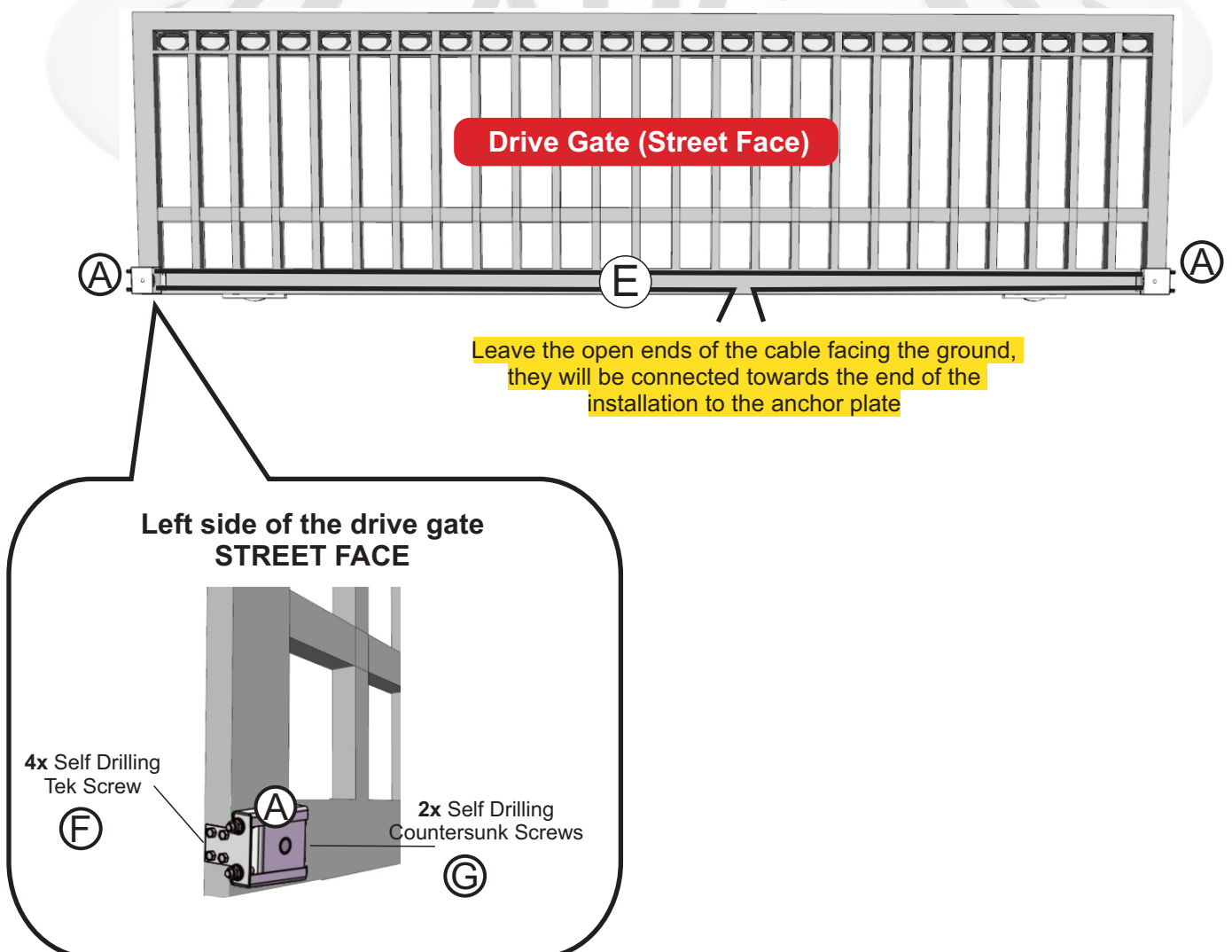

## Fitting the Drive Gate In Place

1. Sit one piece of sliding gate track in front of the MID post.
2. Sit the drive gate on top of the sliding gate tracks using the roller/bracket system or guide block system as the top guide.
3. Sit the remaining tracks in place
3. Slide the gate back and forth ensuring all pieces are in the correct position and that the gate is plumb. Realign the pieces if necessary.
4. Drill track holes using a 6mm masonry bit and fix in place using Ramset Shuredrive Metal Sleeved nails 6x30mm Minimum or preferably 6x50mm.  
Ramset Part number:  
6x30mm SDM06030  
6x50mm SDM06050
5. Install the open position gate stop for the Drive Gate/



## Preparing FOR The Trailing Gate

Install the guide system to the street side of the drive gate in the TOP CORNER closest towards the centre of the driveway.



### Guide Block System (GB-WH-CC)

Drill and fit using 3x 6mm Pan head self drilling screws



### 100mm Rollers and Bracket System (GRB-P100)

Drill and fit using 4x 10mm Tek screws



## Fitting the Trailing Gate In Place

1. Sit one piece of sliding gate track In front of the Drive Gate.
2. Sit the Trailing gate on top of the sliding gate tracks using the roller/bracket system or guide block system as the top guide.
3. Sit the remaining tracks in place
3. Slide the gate back and forth ensuring all pieces are in the correct position and that the gate is plumb. Realign the pieces if necessary.
4. Drill track holes using a 6mm masonry bit and fix in place using Ramset Shuredrive Metal Sleeved nails.
5. Install the open position gate stop for the Drive Gate/

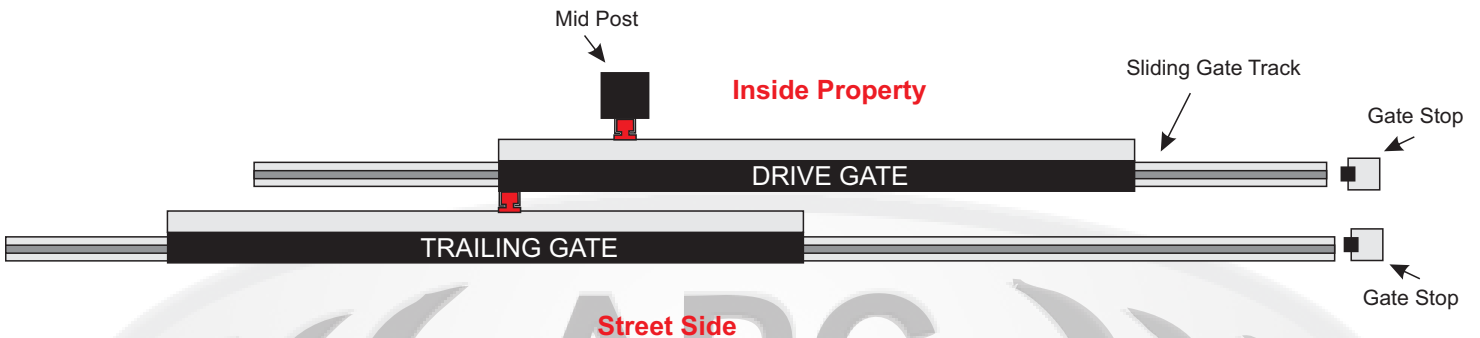

## Installing the Anchor Plate

Before beginning the next steps ensure that you have prepared your anchor plate according to the illustration on page 4.

1. Open both gate flush with the edge of the Mid Post, this is there full open position
2. Install the anchor bracket (C) 10mm from the edge of the carrier (closest to the driveway) to the edge of the bracket using the supplied 4x M8x80 Dynabolts (H).

It must be noted that the cable passes through this bracket in the next step so it must be installed in the cables path were they pass through the pulley carrier.

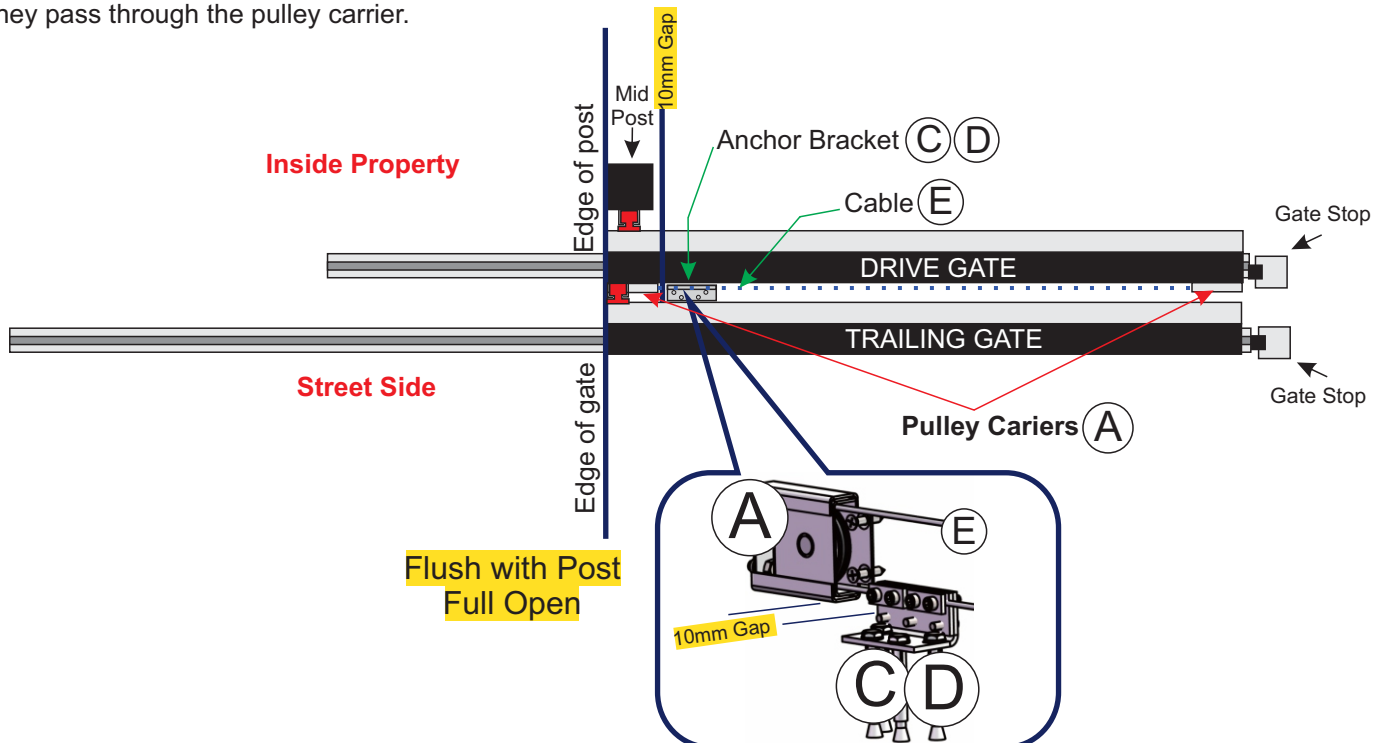



## Fitting the Cable Through The Anchor Bracket

1. Feed one end of the cable through the bracket as illustrated below and tighten both locking bolts. The first end to be feed through should be the one closest to the centre of the gate.
2. Pull the other end of the cable TIGHT using multigrips or pliers and feed it through the anchor bracket also as illustrated below and tighten both locking bolts.

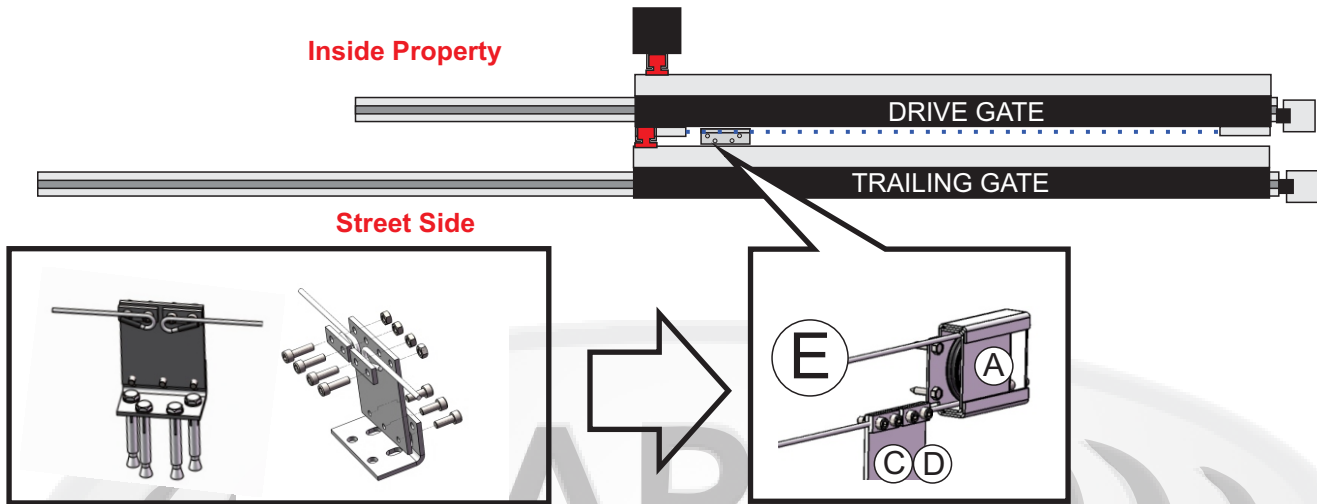

## Tensioning The Cable At The Pulley Carriers

At each of the pulley carriers there are two tensioning nuts, each of these nuts can be tightened to pull the carrier further towards the end of the gate providing a greater tension on the stainless steel cable. It is important to have the cable tensioned correctly and not Over tightened or Loose. The ideal tension is 10mm TOTAL movement (UP/DOWN) from the cables natural parallel path (20mm total).

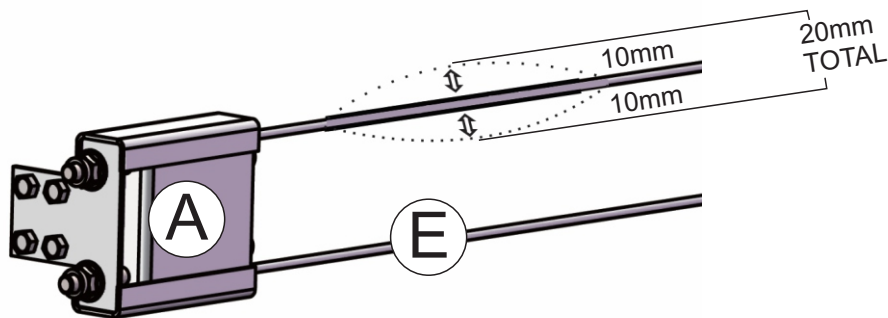

## Cutting The Excessive Cable

At this point we need to cut down the stainless steel cable as it will interfere with the gate.

1. Tape the ends with electrical tape in which you plan to cut.
2. Using a stainless steel wire cutter cut through the cable, if this is not available to you an angle grinder can be used but you must adhere to all safety requirements whilst doing so.
3. Using heat shrink tubing seal the cut end of the cable to prevent fraying in the future.

## Installing The Trailing Bracket

1. Whilst the gate is still open fit the trailing bracket (B) to the trailing gate using 4x Tek Screws (F) with a 10mm gap between the pulley carrier (CLOSEST to the stop) and the edge of the bracket.
2. Snake the cable through the top of the bracket installing one bolt at a time.

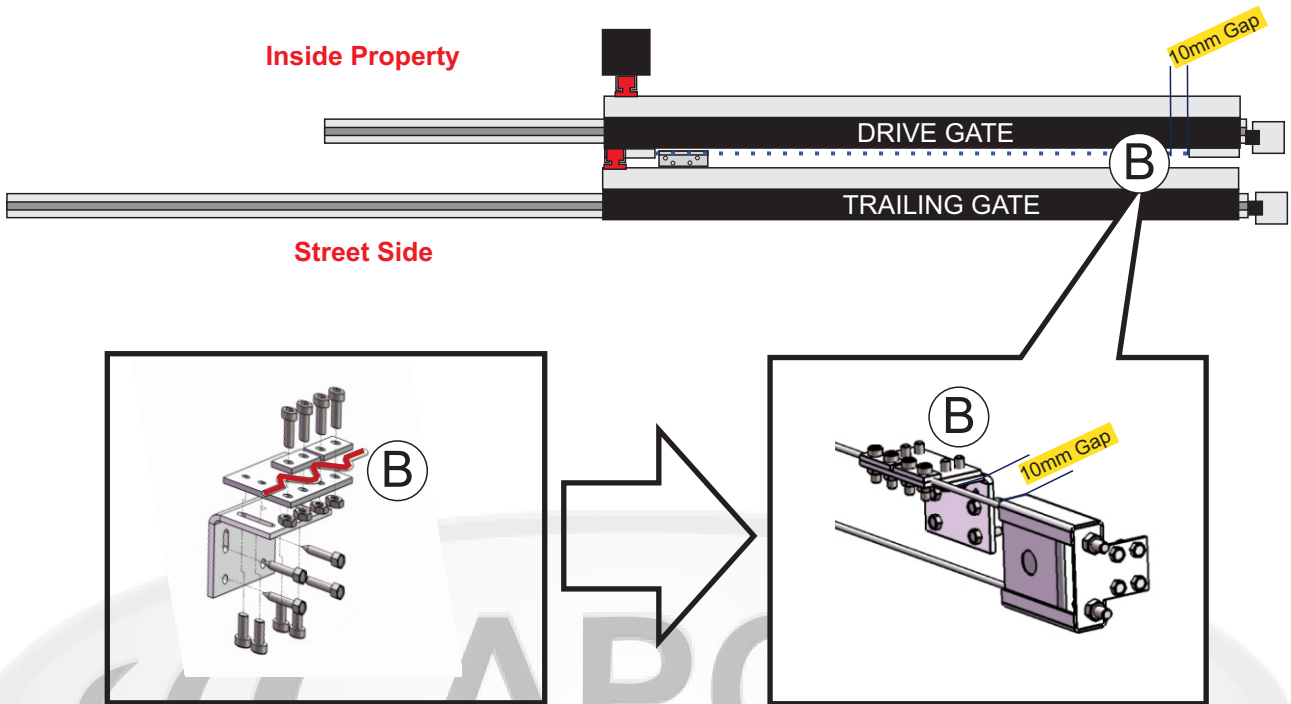

## Available Hardware

### Automation Systems



**Galvanized Steel Track**  
1m, 2m and 3m Lengths



**Aluminium Z Channel**  
1m, 2m and 3m Lengths



**Nylon Rollers**  
60mm, 100mm,  
150mm & 250mm Long



**Rollers Angle Bracket**  
110x165mm  
200x165mm



**Sliding Gate Stopper**  
115mm High

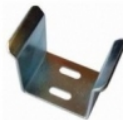

**U Guide Receiver**  
55mm, 65mm & 75mm



**Guide Block  
C Channel**

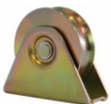

**Flat Mount Wheels**  
68mm & 78mm  
Diameter



**Recess Mount Wheels**  
68mm, 78mm & 98mm  
Diameter

# (((APC))) Automation Systems

## **APC WARRANTY**

APC warrants the original purchasers or the APC gate(s) opening system for a period of twelve months from the date of purchase (not installation), the product shall be free of defects in materials and workmanship under normal use.

During the warranty period, APC shall, as its option, repair or replace any defective product upon return of the product to its factory, at no charge for labour and materials.

Any replacement and/or repaired parts are warranted for the remainder of the original warranty,

The original owner must promptly notify APC in writing that there is defect in material or workmanship, such written notice must be received in all events prior to expiration of the warranty.

## **International Warranty**

APC shall not be responsible for any freight fees, taxes or customs fees.

## **Warranty Procedure**

To obtain service under this warranty, AND AFTER CONTACTING APC, please return the item(s) in question to the point of purchase.

All authorized distributors and dealers have a warranty program, anyone returning goods to APC must first obtain an authorization number. APC will not accept any shipment for which prior authorization has not been used.

## **Conditions to Void Warranty**

This warranty applies only to defects in pairs and workmanship relating to normal use. It does not cover:

- Damage incurred in shipping or handling
- Damage caused by disaster such as fire, flood, wind, earthquake or lightning
- Damage due to causes beyond the control of APC such as excessive voltage, mechanical shock or water damage
- Damage caused by unauthorized attachment, alterations, modifications, or foreign objects.
- Damage caused by peripherals (unless such peripherals were supplied by APC)
- Defects caused by failure to provide a suitable installation environment for the products
- Damage caused by usage of the products for purpose other than those for which it was designed.
- Damage from improper maintenance
- Damage arising out of any other abuse, mishandling, and improper application of the products.

Under no circumstances shall APC be liable for any special, incidental, or consequential damages based upon breach of warranty, breach of contract, negligence, strict liability, or any other legal theory. Such damages include, loss of profits, loss of the product or any associated equipment, cost of capital, cost of substitute or replacement equipment, facilities or services, down time, purchaser's time, the claims of third parties, including customers, and injury to property.

## **Disclaimer of Warranties**

This warranty contains the entire warranty and shall be in lieu of any and all other warranties, whether expressed or implied (including all implied warranties of merchantability or fitness for a particular purpose). And of all other obligations or purporting to act on its behalf to modify or to change this warranty, nor to assume for it any other warranty or liability concerning this product.

## **Out of Warranty Repairs**

APC will at its option repair or replace out-of-warranty products which are returned to its factory according to the following conditions. Anyone returning goods to APC must first obtain an authorization number.

APC will not accept any shipment whatsoever for which prior authorization has not been obtained. Products which APC determines to be repairable will be repaired and returned. A set fee which APC has been predetermined and which may be revised from time to time will be charged for each unit repaired. Products which APC determines not repairable will be replaced by the nearest equivalent product available at that time. The current market price for the replacement product will be charged for each replacement unit.